

NON CUT-OFF STYLE POINT
(SHARP POINT OPTIONAL)

- Designed to resolve the fastening problems of 'stripping' and 'spin-out' in THIN SHEET METAL as is often found when using standard round-bodied sheet metal screws
- Increased torque performance in thin sheet metal applications
- Low end loads
- EXTRUDE-TITE® screws tend to drive straight
- Employs TRILOBULAR™ technology in the joint
- Electrical grounding assured by the intimate contact of the roll-formed threads
- Reduces costs by allowing thinner, lighter materials in the assembly
- Reduces costs by reducing or eliminating repairs due to 'stripping', 'spin-outs', and off-angled entry of fastener on the assembly line
- Reduces costs by eliminating cleanup of chips, oil and debris caused by tapping operations
- Reduces costs by simplifying assembly – fewer components
- Reduces costs by simplifying assembly equipment

SCREW SIZE	SCREW BODY DIMENSIONS				POINT	
	Max.	Min.	Max.	Min.	C _p Maximum	L _p Maximum
Metric Sizes (mm)						
M2.5 x 0.45	2.57	2.48	2.52	2.44	0.94	2.48
M3.0 x 0.50	3.07	2.98	3.02	2.93	1.26	2.75
M3.5 x 0.60	3.58	3.48	3.52	3.42	1.41	3.30
M4.0 x 0.70	4.08	3.98	4.01	3.91	1.56	3.85
M4.5 x 0.75	4.59	4.48	4.51	4.41	1.89	4.13
M5.0 x 0.80	5.09	4.98	5.01	4.90	2.21	4.40
M6.0 x 1.00	6.10	5.97	6.00	5.87	2.51	5.50
M7.0 x 1.00	7.10	6.97	7.00	6.87	3.51	5.50
M8.0 x 1.25	8.13	7.97	8.01	7.85	3.64	6.88
M10 x 1.50	10.15	9.97	10.00	9.82	4.76	8.25
M12 x 1.75	12.18	11.97	12.00	11.80	5.89	9.63
Inch Sizes (in)						
3-48	0.1010	0.0970	0.0990	0.0950	0.026	0.115
4-40	0.1145	0.1105	0.1120	0.1080	0.024	0.138
5-40	0.1275	0.1235	0.1250	0.1210	0.037	0.138
6-32	0.1410	0.1350	0.1380	0.1320	0.028	0.172
8-32	0.1670	0.1610	0.1640	0.1580	0.054	0.172
10-24	0.1940	0.1880	0.1900	0.1840	0.044	0.229
10-32	0.1930	0.1870	0.1900	0.1840	0.080	0.172
12-24	0.2200	0.2140	0.2160	0.2100	0.070	0.229
1/4-20	0.2550	0.2490	0.2500	0.2440	0.076	0.275
5/16-18	0.3180	0.3120	0.3125	0.3065	0.119	0.306
3/8-16	0.3810	0.3750	0.3745	0.3685	0.158	0.344
7/16-14	0.4445	0.4385	0.4375	0.4315	0.190	0.393
1/2-13	0.5075	0.5015	0.5000	0.4940	0.233	0.423

Length Tolerances

Inch

Lengths up to and including 1" ±0.030"
Lengths greater than 1" ±0.050"

Metric

Lengths up to and including 25mm ±0.8mm
Lengths greater than 25mm ±1.3mm

EXTRUDE-TITE® Fasteners

- First prevailing-off torque is an indication of locking torque and resistance to vibrational loosening and was judged favorably high for EXTRUDE-TITE® screws in thin sheet metal.
- Performance in extruded holes is slightly higher than in drilled holes. Therefore, either hole design is favorable.
- EXTRUDE-TITE® screws typically forward and backward extrude material beyond its original thickness, providing the fastener with over twice the engagement than that of non-extruded materials.
- An important consideration is the significantly superior and consistent strip-to-drive ratio of EXTRUDE-TITE® screws over other sheet metal screws which allows for more liberal driver clutch settings at the fastening site.
- Tests have shown that EXTRUDE-TITE® fasteners may be used in a wide range of pilot hole sizes with satisfactory results depending upon application requirements.
- May be used in thicker materials as a thread-forming, locating point fastener.
- Couple EXTRUDE-TITE® fasteners with an underhead locking feature for ultimate vibrational and 'spin-out' resistance or with a sharp point to pierce cloth, vinyl or other such similar materials.

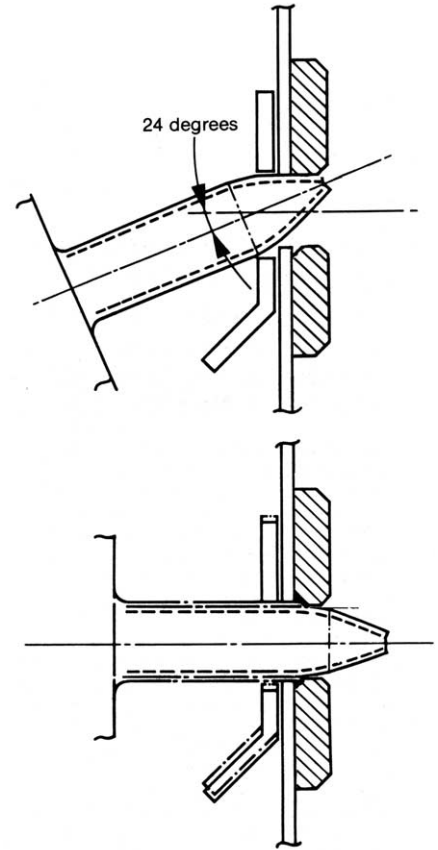

Self-aligning point feature 'finds' the holes, lines them up and fastens components in one operation.

Description	Material Thickness	Hole Size	Drive Torque	First Prevailing Off Torque	Strip Torque	Strip to Drive Ratio	Recommended Tightening Torque
#6 - 32 x 3/8	0.028	0.080	4	2	12	3:1	8
Hex Washer Head	0.032	0.080	5	3	15	3:1	10
Zinc & Wax	0.040	0.080	7	3	21	3:1	14
#8 - 32 x 3/8	0.028	0.110	5	2	15	3:1	10
Hex Washer Head	0.032	0.110	6	3	18	3:1	12
Zinc & Wax	0.040	0.110	10	4	26	2.6:1	18
#10 - 32 x 9/16	0.028	0.138	8	3	25	3:1	17
Hex Washer Head	0.032	0.138	10	4	29	3:1	20
Zinc & Wax	0.040	0.138	15	11	45	3:1	30
1/4 - 20 x 5/8	0.028	0.181	12	6	35	3:1	24
Hex Washer Head	0.032	0.181	14	7	36	2.6:1	25
Zinc & Wax	0.040	0.181	21	10	57	2.7:1	39
M4 x 0.7 x 13	0.70	2.64	0.90	0.32	2.18	2.4:1	1.54
Hex Washer Head	0.80	2.64	1.13	0.39	2.35	2:1	1.74
Zinc & Wax	1.00	2.64	1.32	0.52	2.71	2:1	2.02
M5 x 0.8 x 16	0.70	3.45	0.93	0.35	2.59	2.8:1	1.76
Hex Washer Head	0.80	3.45	1.11	0.73	3.55	3:1	2.33
Zinc & Wax	1.00	3.45	1.66	1.40	4.82	3:1	3.24
M6 x 1.0 x 16	0.70	4.60	1.09	0.48	3.71	3.4:1	2.40
Hex Washer Head	0.80	4.60	1.32	0.52	3.79	3:1	2.56
Zinc & Wax	1.00	4.60	2.12	0.92	6.17	3:1	4.15

TEST PARAMETERS -

Test material: cold-rolled draw quality aluminum killed steel plate hardened to Rb 50-55
 Test washer: .063 thick steel
 Clearance hole: .180(#6), .200(#8), .220(#10), .280(1/4")
 Drive speed: 250 RPM under load
 Driver end load: 8lbs.

- These values may vary proportionately to application. Smaller hole sizes, for example, will increase drive, first off, strip torques, etc. Material thickness will also effect torque/tension values as indicated in the table. These values were derived from averages of over 1800 laboratory tests under specific conditions. These values are to be used only as a guide since actual application performance results may vary.